

Applying large grommets has just become easier! The specially designed **CSBUR-1** offers a wide range of grommet size compatibility including size #12 (1.5"/ 40mm inside dimension) grommets. Designed with an extra long lever and force transfer mechanism, this press generates high mechanical impact making it capable of installing large grommets. It is a reliable, heavy duty machine that doesn't rely on pneumatic or electrical power.

- **Perfect for tarpaulin, tent, truck cover and drapery workshops**
- **Ability to apply #12 (ID: 1.5"/ 40mm) grommets and washers**
- **Extra long lever and force transfer mechanism** engineered to reduce the need of hand force
- **Free standing or bench mounted**
- **"On Cart" version is available:** wheel the press around your large project while it lies on the floor or table. No need to move the product, no need to lift the heavy press.
- **Suitable for applications on various material substrates**
- **Heavy duty durable machine** almost no maintenance required

***Interchangeable die capabilities:***

Unlike most traditional grommet machines that allow only one size of grommet application, all ClipsShop dies are compatible with the CSBUR-1 hand press machine. This feature allows setting many different sizes of grommets by a simple die changing process which takes only seconds.

Master Distributor for  
**CLIPS SHOP**  
In the Americas.

**1 1/2"**  
**#12 GROMMET  
COMPATIBLE!**



## HAND PRESS CSBUR-1

999-2034

# HAND PRESS: CSBUR-1

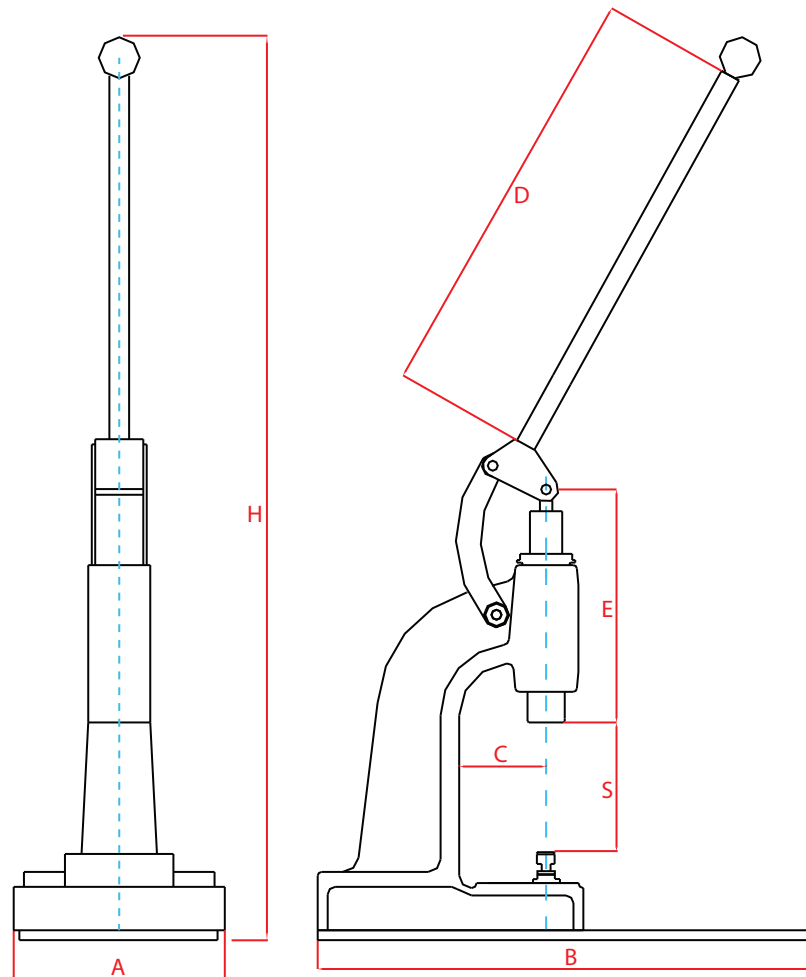

## Dimensions

## Inch / mm

A	6.89 / 175
B	15.75 / 400
C	2.64 / 67
D	13.39 / 340
E	8.07 / 205
S	3.54 / 90
H	30.71 / 780

## Technical Features

Compatible grommet sizes	All standard sizes to #12
Weight	35 lbs / 16kg
Overall dimensions	16.5" h x 6.25" w x 15.75" d

**METAL**.com  
**grommets**